

# Kingtronics®

## KT10N80

### N-Channel Power MOSFET

## FEATURES

10A, 800V,  $R_{DS(on)(typ.)}=0.92\Omega @ V_{GS}=10V$   
 Low gate charge  
 Low Crss  
 Fast switching  
 Improved dv/dt capability

## Schematic Diagram (N-Channel)

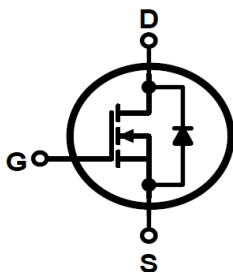

## PRODUCT SUMMARY

$V_{DSS}$	800	V
$I_D$	10.0	A
$P_D(T_C=25^\circ C)$	62	W
$R_{DS(ON)}$	0.92	$\Omega$

### TO-220F

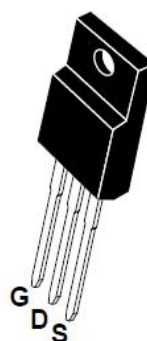

### TO-220

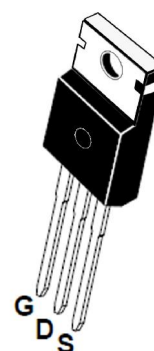

## MAXIMUM RATINGS AND ELECTRICAL CHARACTERISTICS

$T_C = 25^\circ C$  unless otherwise specified

Parameter	Symbol	Rating	Units
Drain-source Voltage	$V_{DS}$	800	V
Gate-source Voltage	$V_{GS}$	$\pm 30$	V
Drain Current	$I_D$	$T_C=25^\circ C$	10.0
		$T_C=100^\circ C$	6.32
Drain Current Pulsed	$I_{DM}$	40	A
Power Dissipation( $T_C=25^\circ C$ ) -Derate above $25^\circ C$	$P_D$	62	W
		0.50	W/ $^\circ C$
Single Pulsed Avalanche Energy(Note 1)	$E_{AS}$	938	mJ
Reverse Diode dv/dt (Note 2)	dv/dt	4.5	V/ns
MOSFET dv/dt Ruggedness (Note 3)	dv/dt	50	V/ns
Operation Junction Temperature Range	$T_J$	$-55 \sim +150$	$^\circ C$
Storage Temperature Range	$T_{stg}$	$-55 \sim +150$	$^\circ C$

Notes:

- $L=30mH$ ,  $I_{AS}=7.50A$ ,  $V_{DD}=100V$ ,  $R_G=25\Omega$ , starting temperature  $T_J=25^\circ C$ ;
- $V_{DS}=0\sim 400V$ ,  $I_{SD}\leq 10A$ ,  $T_J=25^\circ C$ ;
- $V_{DS}=0\sim 480V$ ;

**Kingtronics® International Company**

# Kingtronics®

# KT10N80

## N-Channel Power MOSFET

### RATING AND CHARACTERISTIC CURVES

Figure 1. On-Region Characteristics

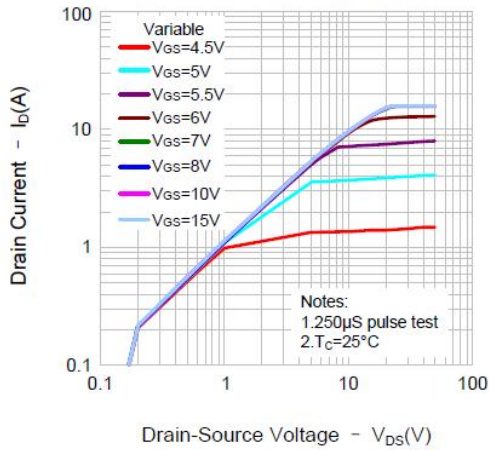

Figure 2. Transfer Characteristics

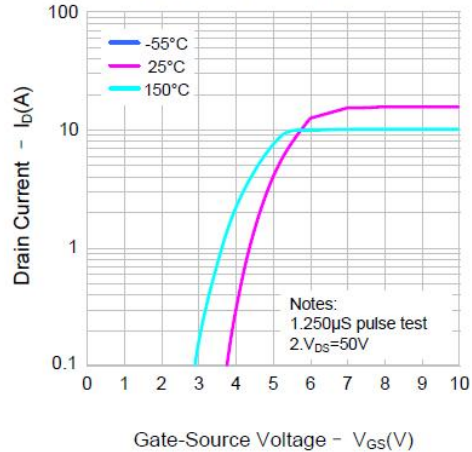

Figure 3. On-Resistance Variation vs. Drain Current and Gate Voltage

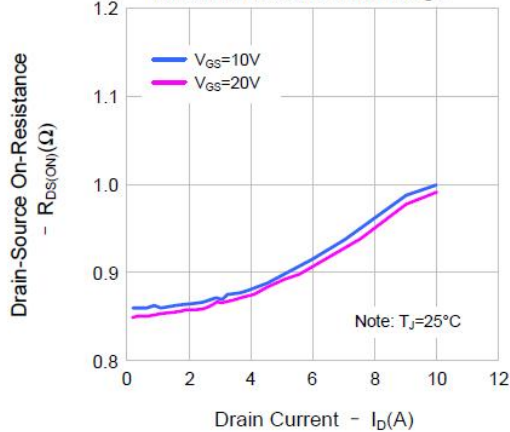

Figure 4. Body Diode Forward Voltage Variation vs. Source Current and Temperature

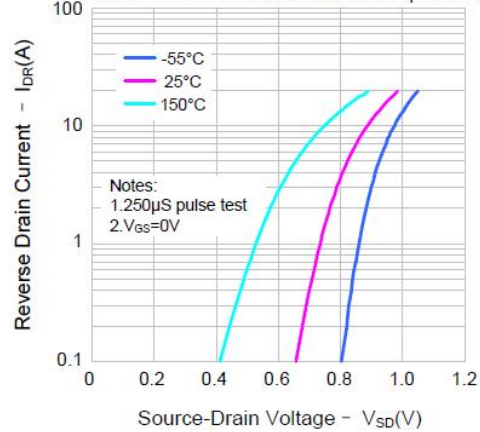

Figure 5. Capacitance Characteristics

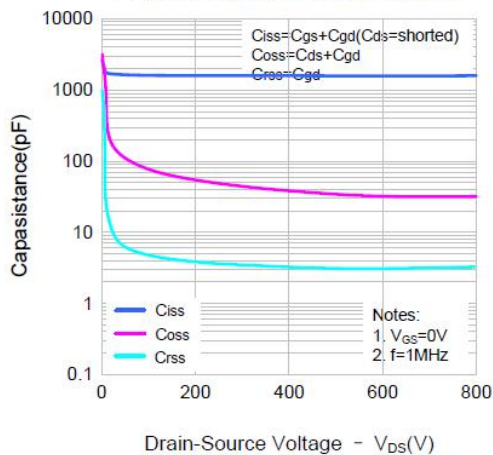
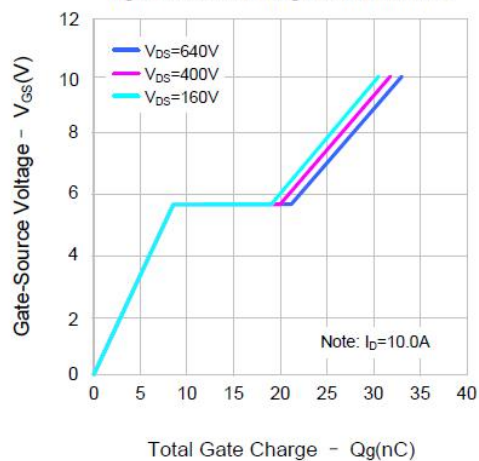

Figure 6. Gate Charge Characteristics



Kingtronics® International Company

# Kingtronics®

# KT10N80

## N-Channel Power MOSFET

Figure 7. Breakdown Voltage Variation vs. Temperature

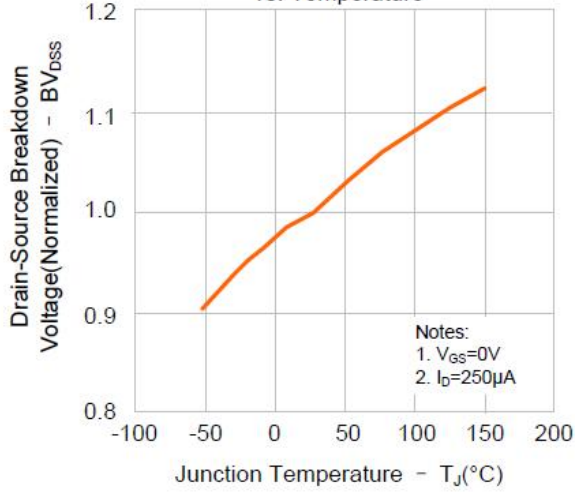

Figure 8. On-resistance Variation vs. Temperature

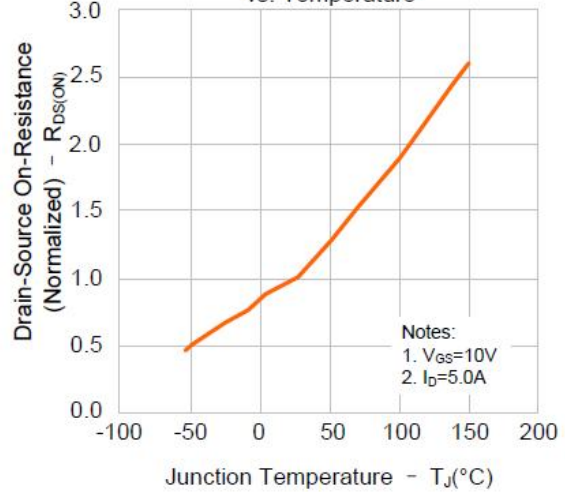

Figure 9 . Max. Safe Operating Area

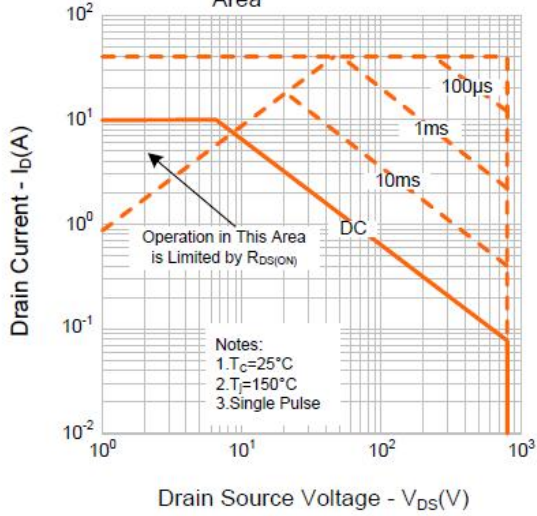
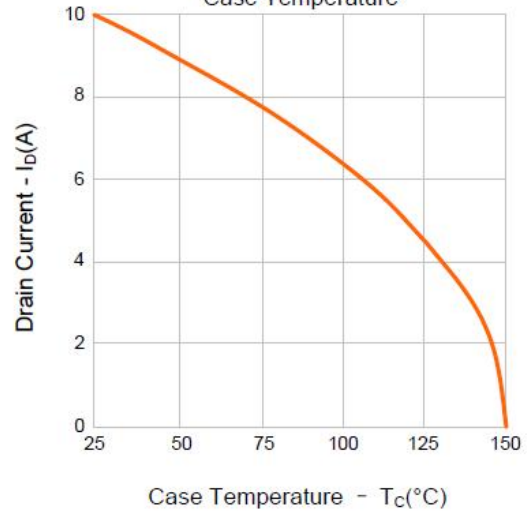

Figure 10. Maximum Drain Current vs. Case Temperature



**Kingtronics® International Company**

# Kingtronics®

## KT10N80

### N-Channel Power MOSFET

## Package Dimensions

### TO-220

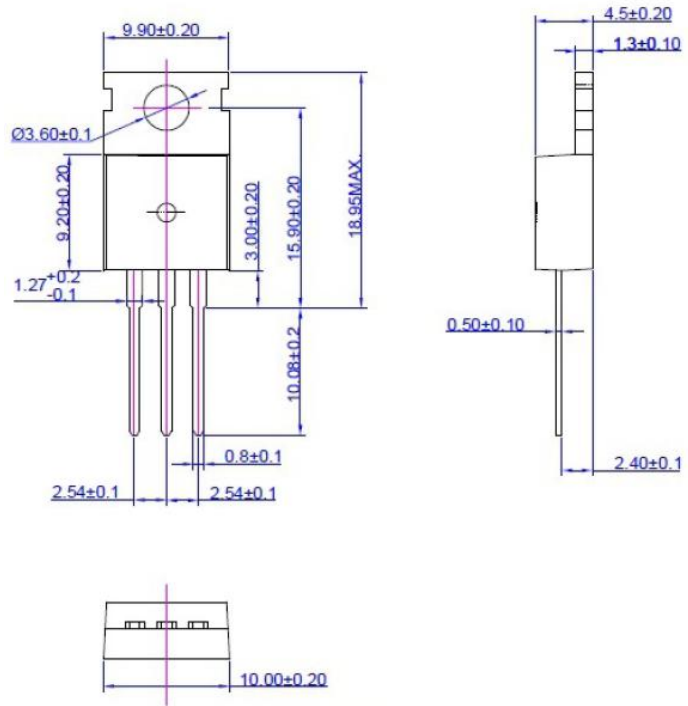

### TO-220F

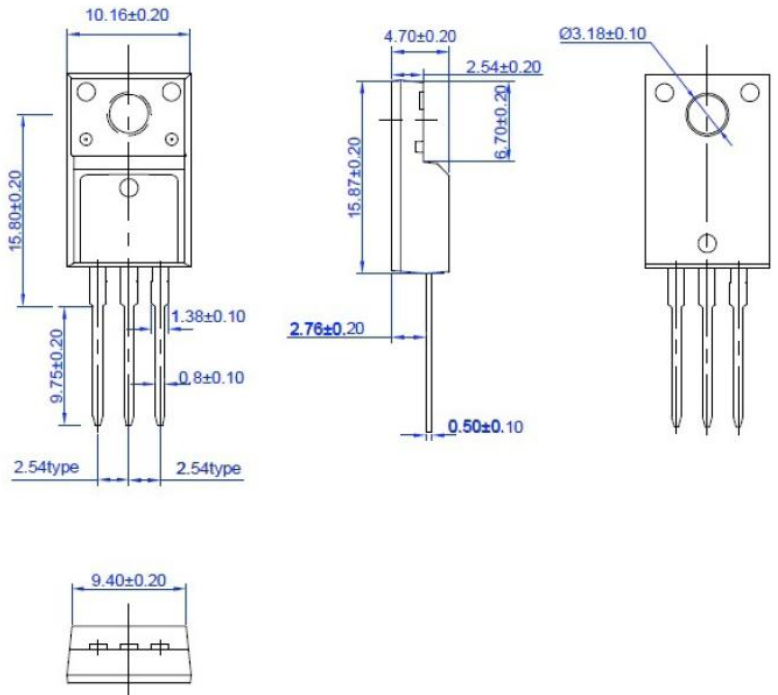

Notes: Specifications are subject to change without notice.

**Kingtronics® International Company**

Website: [www.kingtronics.com](http://www.kingtronics.com) Email: [info@kingtronics.com](mailto:info@kingtronics.com) Tel: (852) 8106 7033 Fax: (852) 8106 7099