

## TRANSISTOR

Marking:L6

Suggested Layout

SOT-23

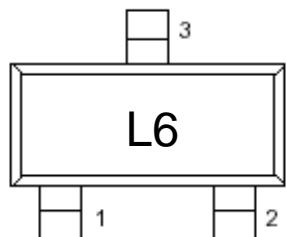

Top view

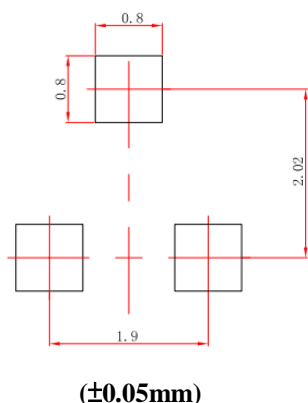
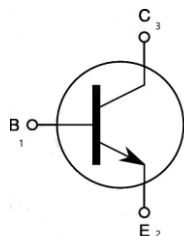

Dimension

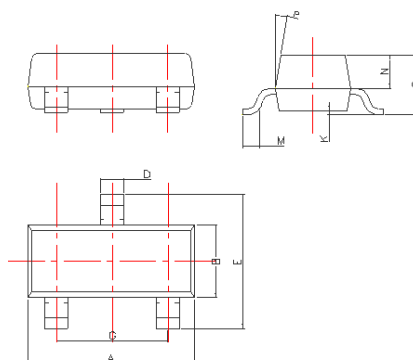

DIM	Millimeters
A	2.85~3.04
B	1.30±0.10
C	1.00±0.10
D	0.45±0.05
E	2.25~2.55
G	1.90±0.1
K	0.00-0.10
M	0.20 min
N	0.60±0.10
P	7±2°

### MAXIMUM RATINGS (Ta=25°C)

Characteristic	Symbol	Rating	Unit
Collector-Emitter Voltage	$V_{CEO}$	50	Vdc
Collector-Base Voltage	$V_{CBO}$	60	Vdc
Emitter-Base Voltage	$V_{EBO}$	5.0	Vdc
Collector Current - Continuous	$I_C$	100	mAdc
Base Current	$I_B$	30	mAdc

### THERMAL CHARACTERISTICS

Characteristic	Symbol	Max	Unit
Collector Power Dissipation	$P_c$	300	mW
Junction and Storage Temperature	$T_j$ , $T_{stg}$	150, -55 ~ 150	°C

### ELECTRICAL CHARACTERISTICS (TA=25°C unless otherwise noted)

Characteristic	Symbol	Test Condition	Min	Type	Max	Unit
Emitter Cutoff Current	$I_{EBO}$	$V_{EB}=5V, I_C=0$	--	--	0.1	μA
Collector-Emitter Breakdown Voltage	$V_{(BR)CEO}$	$I_C=1.0mA$	50	--	--	V
Collector-Base Breakdown Voltage	$V_{(BR)CBO}$	$I_C=100\mu A$	60	--	--	V
Emitter-Base Breakdown Voltage	$V_{(BR)EBO}$	$I_E=100\mu A$	5	--	--	V
DC Current Gain	$h_{FE}$	$V_{CE}=6V, I_C=1mA$	200	--	400	--
Collector-Emitter Saturation Voltage	$V_{CE(sat)}$	$I_C=100mA, I_B=10mA$	--	0.15	0.3	V
Base-Emitter Saturation Voltage	$V_{BE(sat)}$	$I_C=100mA, I_B=10mA$	--	0.86	1.0	V
Base-Emitter Voltage	$V_{BE}$	$V_{CE}=6.0V, I_C=1mA$	0.55	0.62	0.65	V
Transition Frequency	$f_T$	$V_{CE}=6.0V, I_C=10mA$	--	250	--	MHz
Collector Output Capacitance	$C_{ob}$	$V_{CB}=6V, I_E=0, f=1MHz$	--	3.0	--	pF

# Kingtronics®

# CDT1623L6-ME

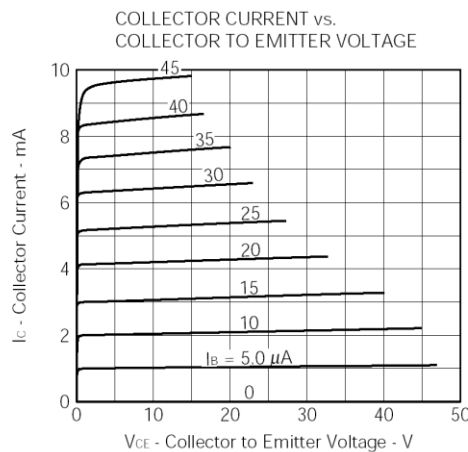
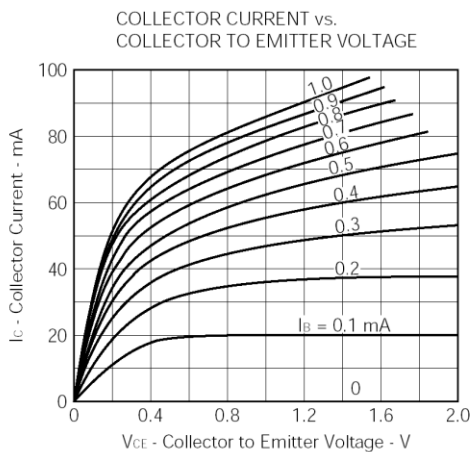
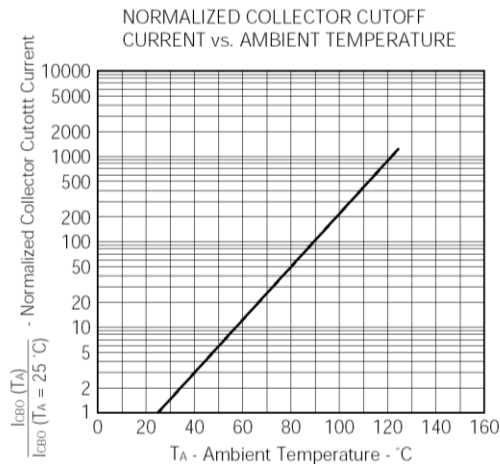
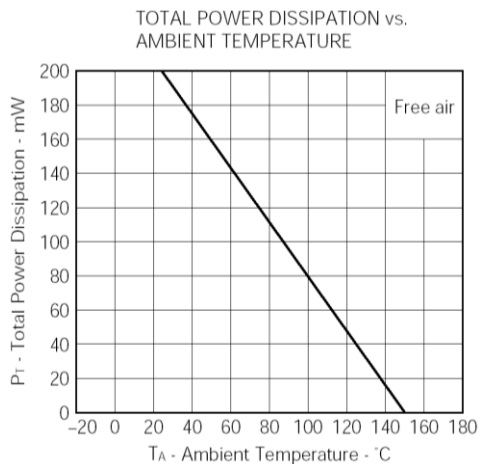

DC CURRENT GAIN vs. COLLECTOR CURRENT



DC CURRENT GAIN vs. COLLECTOR CURRENT

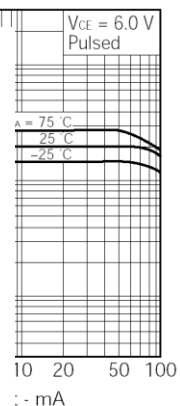
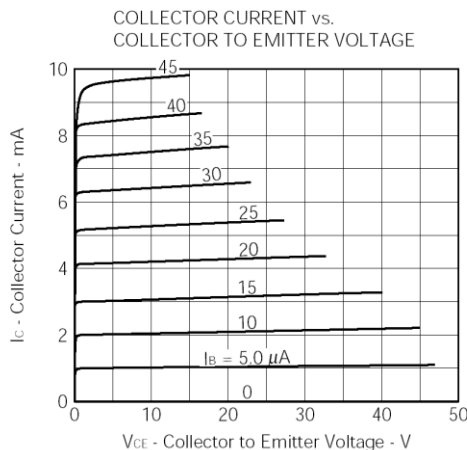
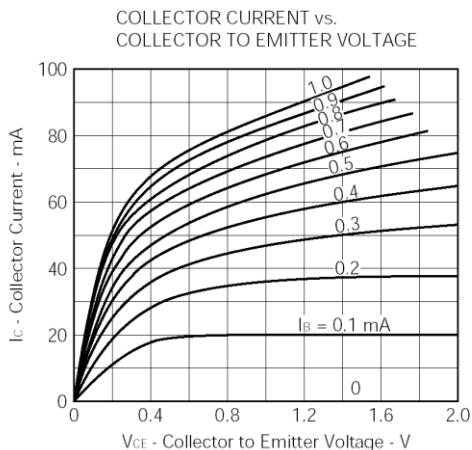

**Kingtronics® International Company**

## Typical Performance Characteristics

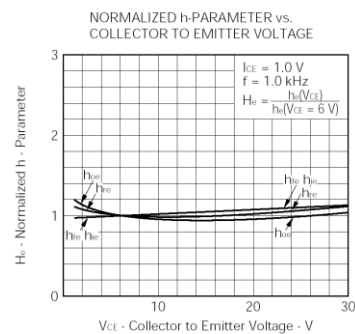
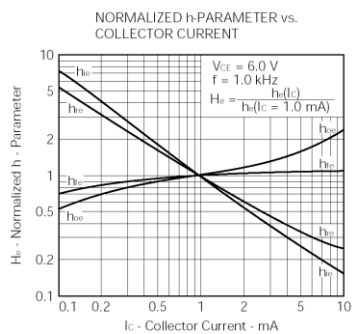
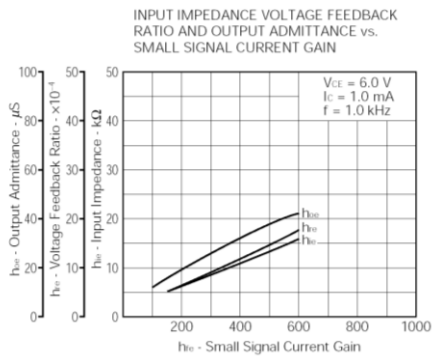
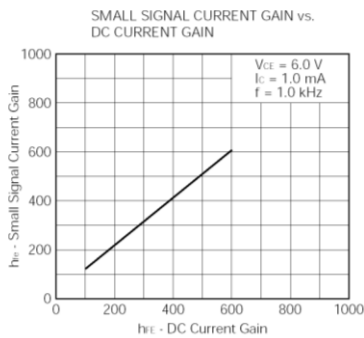
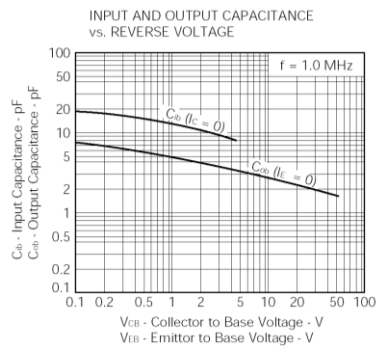
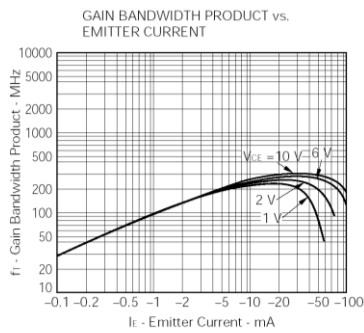
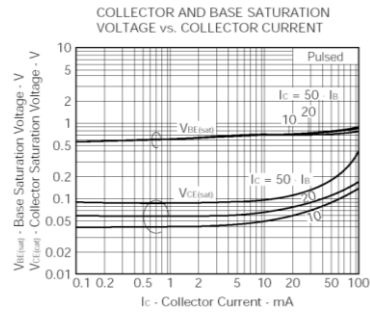
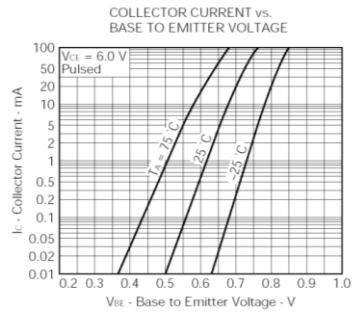

Note: Specifications are subject to change without notice.