

Kingtronics®

YKT-3W0

Hybrid Tantalum Capacitor

FEATURES

- ◆ Tantalum case, Hermetically Sealed, Cylindrical, Radial-lead, Heteropolarity, with screws, convenient to fix.
- ◆ Commingled by Electrolytic Tantalum Capacitor and Electrochemical Capacitor, Small size, Super Capacitance.
- ◆ Stable in Electrical Performances, High Reliability, Long life-span, Maximum in the Density of Capacitance and Energy, Nominal Capacitance is higher than YKT-2W0 series.
- ◆ Built-in as battery in Energy-conversed-circuit & Power-pulsed-circuit, functioned as filtering, storage energy, time-delay circuit.



SPECIFICATIONS

Operating Temperature	-55°C to +125°C (to +125°C, with rated voltage derating)
Storage Temperature	-62°C ~ +130°C
Capacitance Tolerance	Q: (-10%~+30%), K: (±10%), M: (±20%)

Electrical Characteristics

Rated Voltage (V)	Category Voltage (V)	Surge Voltage (V)	Cap. (µF)	tgδ (%)	ESR (Ω) 1kHz	DCL (µA)		Impedance at (Ω) 100Hz	Capacitance Change at (%)			Dimensions
						25°C	85°C, 125°C		-55°C	-55°C	+85°C	DxH
								(mm)				
10	6	11	20000 230000	190	0.025	300	1800	1	-80	+160	35.5x20 35.5x24	
16	9.5	17.6	120000 140000	170	0.025	300	1800	1	-80	+160	35.5x20 35.5x24	
25	15	27.5	70000 86000	140	0.025	300	1800	1	-75	+160	35.5x20 35.5x24	
35	20	38.5	50000 60000	100	0.025	300	1800	1	-70	+160	35.5x20 35.5x24	
50	30	55	30000 30000 32000 33000 33000	75	0.025	400	2400	1.2	-60	+160	35.5x18.4 35.5x20 35.5x20 35.5x20 35.5x24	
63	38	70	16000 18000	55	0.035	400	2400	1.4	-50	+100	35.5x20 35.5x24	
80	48	88	11000 13000	45	0.035	500	2500	1.6	-40	+100	35.5x20 35.5x24	
100	60	110	4800 6000 7500	40	0.035	500	2500	1.8	-30	+80	35.5x20 35.5x20 35.5x24	
125	75	138	2200 4500 4700 2800 4500 4700	35	0.050	500	2500 3000 3000 2500 3000 3000	2.4 2.5 2.4 2.4 2.0 2.0	-25 -25 -25 -20 -25 -25	+50 +50 +50 +40 +45 +45	35.5x20 35.5x20 35.5x20 35.5x24 35.5x24 35.5x24	

Kingtronics® International Company

Kingtronics®

YKT-3W0

Hybrid Tantalum Capacitor

DIMENSIONS (mm)

Φ35.5x18.4/20/24 Layout

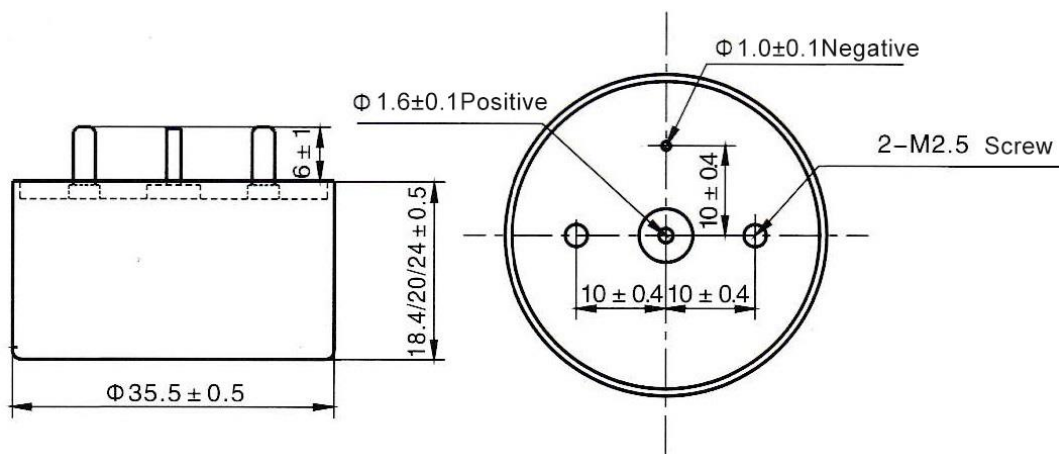

Note:

1. Please do not use multimeter through the measuring procedures (may cause irreversible damage and lead to discard).
2. Capacitance and DF measured at 100Hz, $U_{-}=2.200-1.0V$, $U_{\sim}=1.00-0.5V$ Test only applied in series equivalent circuit.
3. Voltage derating is applied at $+125^{\circ}C$. (The DCL parameter should be read after 5 minutes when it connected to the circuit).
4. Special size and demand could consult with us.

Note: Specifications are subject to change without notice.

Kingtronics® International Company

Website: www.kingtronics.com Email: info@kingtronics.com Tel: (852) 8106 7033 Fax: (852) 8106 7099