

Kingtronics®

CDT8050-ME(Sn)

TRANSISTOR

Marking: Y1'

Suggested Layout

SOT-23

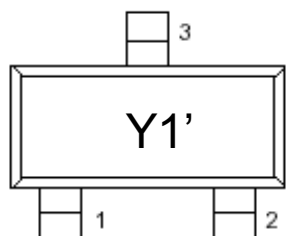

Top view

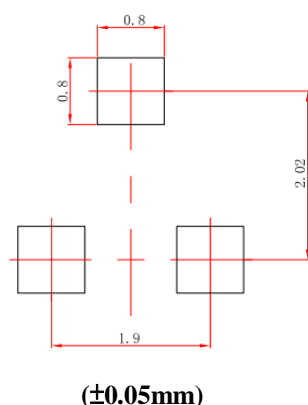
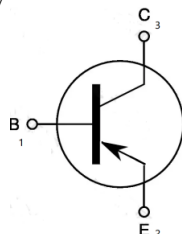

Dimension

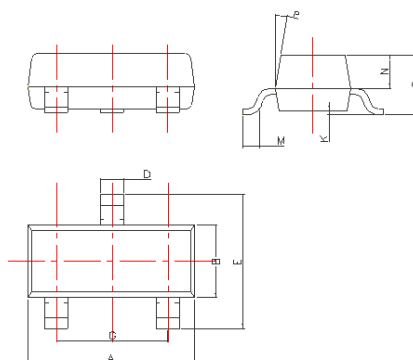

DIM	Millimeters
A	2.85~3.04
B	1.30±0.10
C	1.00±0.10
D	0.45±0.05
E	2.25~2.55
G	1.90±0.1
K	0.00-0.10
M	0.20 min
N	0.60±0.10
P	7±2°

MAXIMUM RATINGS (Ta=25°C)

Characteristic	Symbol	Rating	Unit
Collector-Emitter Voltage	V_{CEO}	25	Vdc
Collector-Base Voltage	V_{CBO}	40	Vdc
Emitter-Base Voltage	V_{EBO}	5.0	Vdc
Collector Current - Continuous	I_C	1500	mAdc
Base Current	I_B	160	mAdc

THERMAL CHARACTERISTICS

Characteristic	Symbol	Max	Unit
Collector Power Dissipation	P_c	300	mW
Junction and Storage Temperature	T_j , T_{stg}	150 , -55 ~150	°C

ELECTRICAL CHARACTERISTICS (TA=25°C unless otherwise noted)

Characteristic	Symbol	Test Condition	Min	Type	Max	Unit
Collector Cutoff Current	I_{CBO}	$V_{CB}=30V, I_E=0$	--	--	0.1	μA
Collector- Emitter Cutoff Current	I_{CEO}	$V_{CB}=20V, I_E=0$	--	--	0.1	μA
Emitter Cutoff Current	I_{EBO}	$V_{EB}=5V, I_C=0$	--	--	0.1	μA
Collector-Emitter Breakdown Voltage	$V_{(BR)CEO}$	$I_C=10mA$	25	--	--	V
Collector- Base Breakdown Voltage	$V_{(BR)CBO}$	$I_C=100\mu A$	40	--	--	V
Emitter-Base Breakdown Voltage	$V_{(BR)EBO}$	$I_E=100\mu A$	5	--	--	V
DC Current Gain	$h_{FE(1)}$	$V_{CE}=1V, I_C=100mA$	200	--	350	--
	$h_{FE(2)}$	$V_{CE}=1V, I_C=1.5A$	40	--	--	
Collector-Emitter Saturation Voltage	$V_{CE(sat)}$	$I_C=1200mA, I_B=120mA$	--	--	0.6	V
Base Emitter Voltage	V_{BE}	$V_{CE}=1V, I_C=10mA$	100	0.8	1.2	V
Transition Frequency	f_T	$V_{CE}=5V, I_C=10mA$	--	120	--	MHz
Collector Output Capacitance	V_{ob}	$V_{CB}=10V, I_E=0,$ $f=1MHz$	--	13	30	pF

- FR-5=1.0x0.75x0.062in.
- Alumina=0.4x0.3x0.024in, 99.5% alumina.
- Pulse Width ≤300μS; Duty Cycle ≤2.0%

Kingtronics® International Company

Typical Performance Characteristics

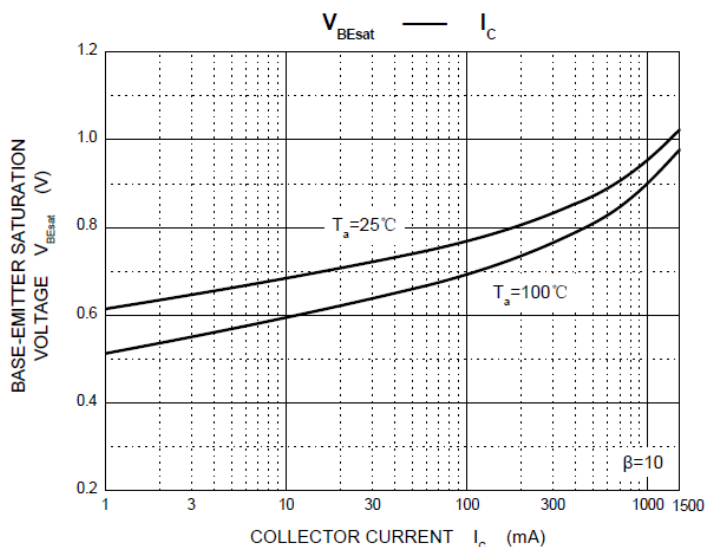
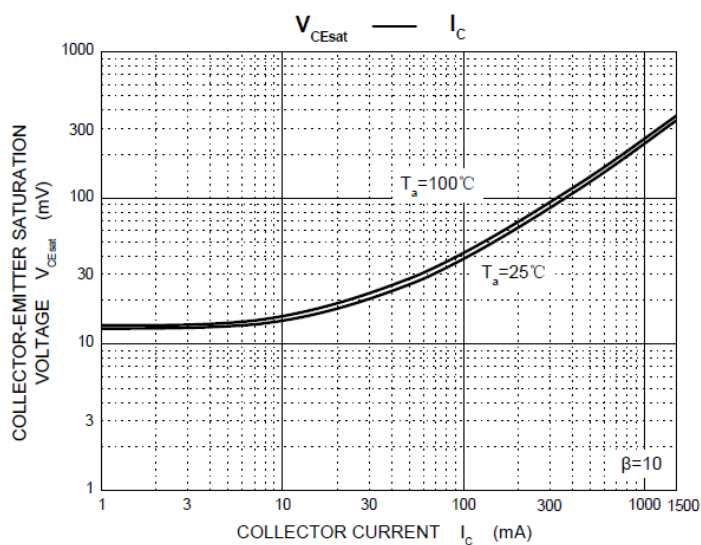
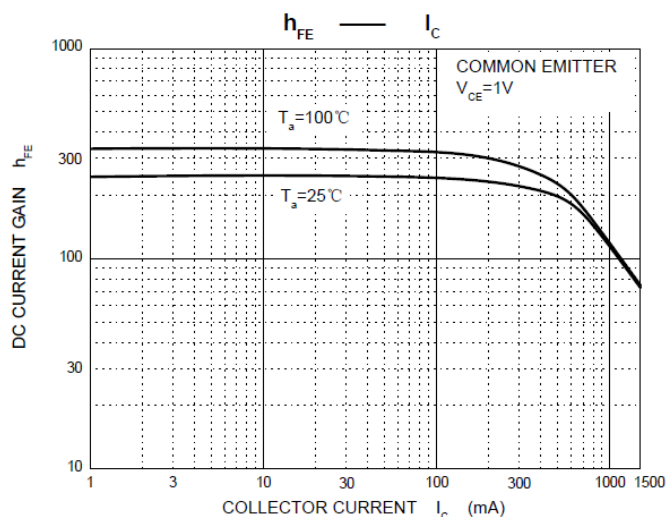
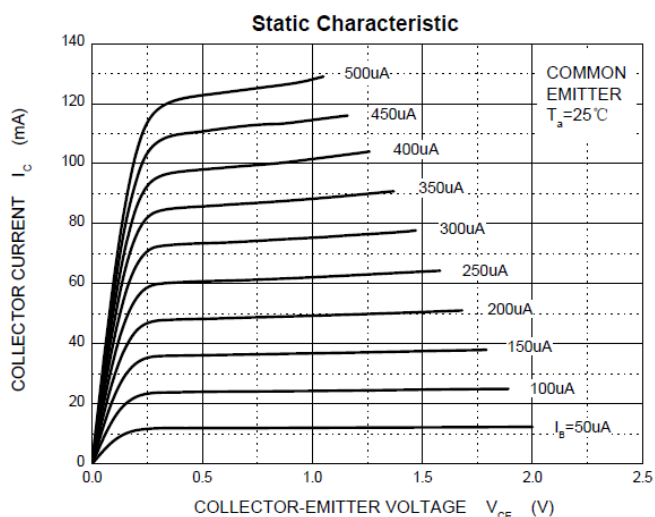

Kingtronics®

CDT8050-ME(Sn)

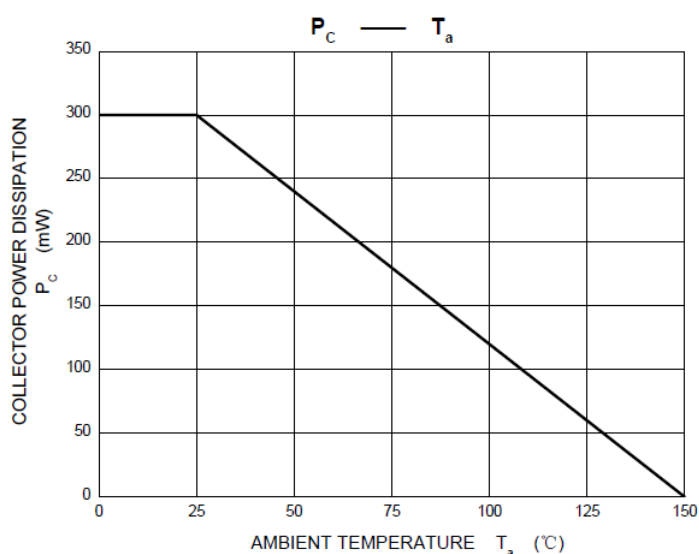
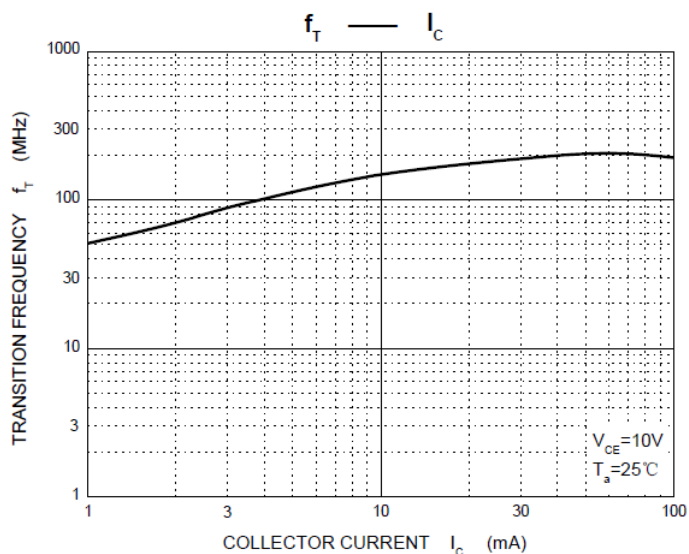
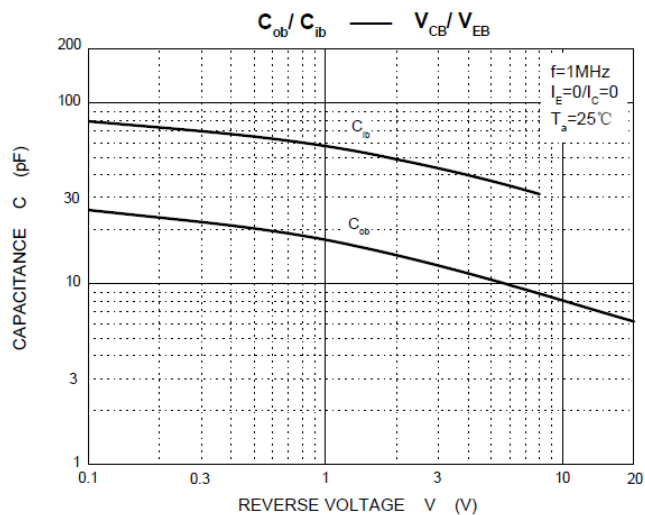
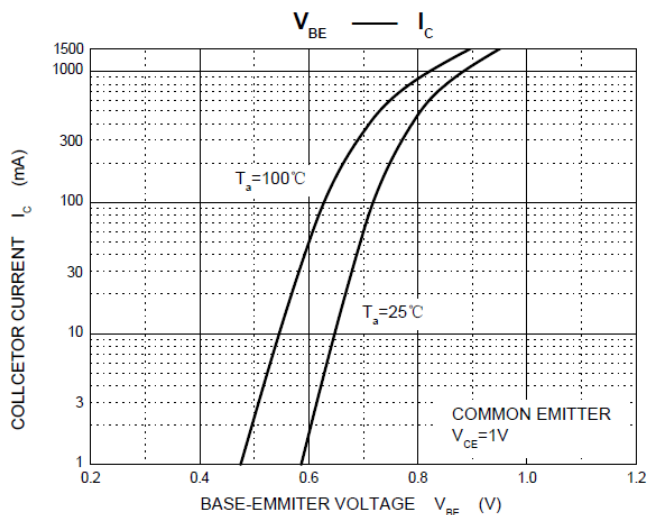

Note: Specifications are subject to change without notice.

Kingtronics® International Company

Website: www.kingtronics.com Email: info@kingtronics.com Tel: (852) 8106 7033 Fax: (852) 8106 7099